

Robotic Control Using an Android Application

Saurabh Khoje¹, Devendra Urad², Monika Shirke³, Prof. Anita Shinde⁴
^{1,2,3,4}Department of Computer Engineering,

Marathwada Mitra Mandal's College of Engineering(MMCOE), Pune

Abstract - Nowadays we can see that things which were previously controlled manually are automated using machines and electronic remote controls. The main objective of this paper is to create an Android application which can be used to control the robot using wireless technology. Nowadays Android is the most popular operating system used for smart devices. Smart devices which are using the Android platform are also becoming more popular these days because of its smart and easy to use touch interface. Also hardware technology utilized in smart phones is improving significantly day by day. Hence, we can say that using such a powerful and generalized platform of the Android smart phones to control the robotic or any other system will be the great advantage for industrial and other general purpose use. The wheeled robot is used in this paper will be able to connect with an Android smart phones using HC05 Bluetooth module. The closed loop system is implemented in the robot using PID (proportional, integrated, derivative) controller will provide us the constant feedback of the current status of performance of the robot. By using that feedback from the PID system errors in the system will be reduced and consistency of the performance of the system will be maintained.

Keywords - Robotic control, Proportional-Integral-Derivative (PID) controller, Android platform, Bluetooth connectivity

I. INTRODUCTION

Robots are smart electromechanical machines which can be designed and programmed to complete various tasks in industries, production lines, logistics, manufacturing and health industries. Robots are able to perform their assigned tasks with precision and pin point accuracy. They are more accurate, fast and rigorous in performance as compared to humans. Nowadays robotic systems are becoming more and more advance because of implementation of Artificial Intelligence algorithms. With the help of Artificial Intelligence, robotic systems have become smart enough to take some decisions all by themselves up to certain level. Hence their compatibility, credibility and scalability have increased significantly. In this way robotic systems are developing day by day and in near future they will be able to perform daily chores of humans in a smart way. In this paper, we are proposing the architecture in which a wheeled robot will be controlled by an Android application. Connectivity between robot and smart phone will be established by the Bluetooth technology. This android application should control the wheeled robot using HC05 Bluetooth module. Robot will receive the data from android device. This data will be received by Bluetooth module first then it will forward the data to ATmega-16 micro-controller using UART. Micro-

controller will process the data and output of this will be movement of the robot according to the input given by user.

There will be two modes by which we will be controlling the robot. First mode is the basic mode. In this mode user will give input using buttons provided on screen. There will be 7 buttons. Out of this 7 buttons 4 will be controlling the direction of the robot. These 4 direction buttons will be used to move the robot in forward direction, backward direction, left direction and right direction. Two buttons will be used for acceleration and braking. There will be one help button which will provide help to the new users handling the application for first time.

Second mode is advance mode. In this mode there will be only one help button which will provide help to new users. In this mode user needs to draw the pattern on screen which will be used by the robot to travel the path. In advance mode we will give dimensions of the physical area for which robot needs to follow the given pattern.

This paper is organized as follows. Section 2 related work regarding this topic. Section 3 explains system architecture. Section 4 gives technical specifications of robotic components. Section 5 gives significance of using PID in the robotic system. Section 6 concludes the paper.

II. RELATED WORK

Different types of researches have been made to develop android device controlled robotic system. Application domains considered for these researches are different .Hence researchers have proposed different architecture for android application and robotic system.

Jorge Kazacos Winter [2] has developed android controlled mobile robot. Objective of his project was wireless Internet data transfer between smart phone and robot and developing the robot and its communication system under a low cost and open source philosophy. He has used 3D designing technique to design the robotic structure with the help of parametrical modeling software .This design can be fed to the 3D printer which will print the robotic components layer by layer and then using these components robot can be assembled easily .He has used Arduino micro-controller and Wi-Fi connectivity in this robot.

M.Selvam [4] has proposed architecture to develop a robotic system attached with wireless camera for the purpose of surveillance. He has used Bluetooth technology for connectivity between robot and smart phone. He has used wireless night vision camera for remote surveillance. Video captured by camera is transmitted to TV unit through RF signal .He has used 8051 micro controller for robotic system.

Vito M Guardi [1] have proposed a design of a Bluetooth technology .Android application for micro-controller driven robot .The main objective of his work is to show that a single android application is capable of working with different electronic devices typically used within the hobby and armature robotic field .He has developed a communication protocol for android smartphone and robotic platform over a Bluetooth technology connectivity .He has used ActivityBot Robot Kit manufacture by Parallax and Propeller micro-controller board which contains 8 independent 32 bit processors and RN-42 Bluetooth technology adapter by Parallax for robotic system.

Ranjith Kumar Goud and B.Santhosh Kumar [3] have developed android controlled robotic architecture for pick and retaining of objects. Main objective of their work was creating a pick and retain robot which can be used for a bomb diffusion from safe distance .They have used 2 motors for robotic hand and 2 motors for robots wheels to control the movement .They have used LPC2148 micro-controller, wireless camera for remote surveillance and Bluetooth module for connectivity. They have developed this project by keeping in mind its industrial and military applications.

III. SYSTEM ARCHITECTURE

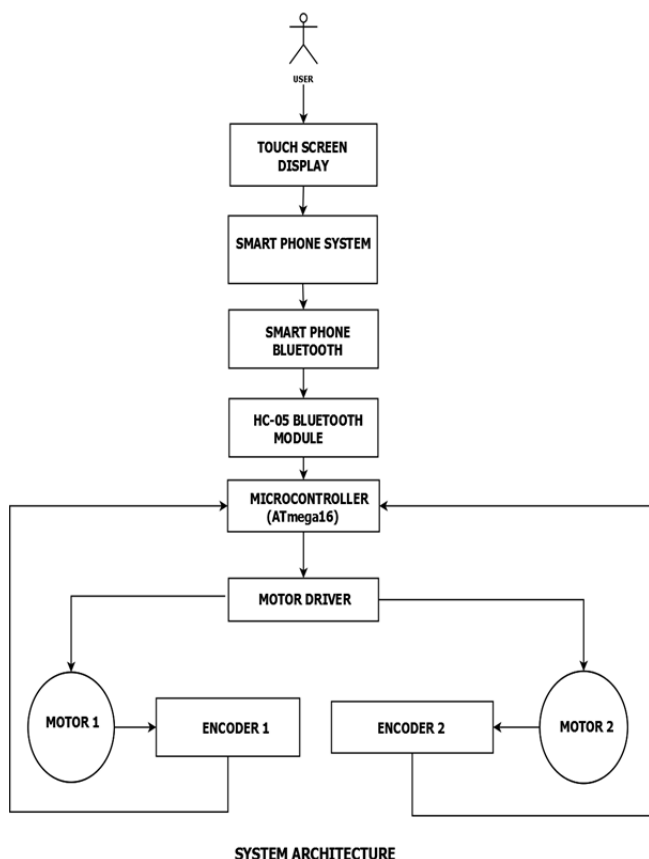

In this paper, our system consists of two sub-systems one is an Android smart phone and another is robotic system. Both the systems will be connected wirelessly using Bluetooth technology. Sub-system 1 will be controlled by the user with the help of touch interface of

the application. Commands given by user will be sent to the robot via Bluetooth. Robot will receive the commands, process them and perform the actions according to that. Robotic system will be able to send back feedback or notification to the smart phone to notify the user about current status of the system.

Sub-system 2 is a robotic system which is basically a wheeled robot. ATmega-16 microcontroller is used in this robot to control the whole system. It has HC-05 Bluetooth module which receives the data from smart phone and feeds it to the microcontroller. Then this data is processed and robot will perform the commanded operations. Robot has 2 DC motors attached to the rear wheels to perform movements. Motor driver L298 is used to drive these motors. Quadrature encoders are used for precise and smooth operation of the robot. PID equation is used in the robotic sub-system to control the output of the system.

IV. TECHNICAL SPECIFICATION OF ROBOTIC COMPONENTS

A. ATmega16

ATmega16 is 8 bit AVR microcontroller, used for low level application. It has 16 kb programmable flash memory. It has 10 bit ADC channel which is used for analog to digital conversion. It has three external interrupts handling capacity which is used in this paper for encoder pulse counting and polling. It also has 4 PWM channel out of which two are 8 bit and two are 16 bit. ATmega16 has 4 i/o port, every port is 8 bit wide.

B. DC Motor

DC motor is one type of rotary actuator which is having number of application in industry. DC motor is specified by its RPM and torque (kg/cm). For the robotic system, 300 RPM and 3kg/cm torque motor is used to bear load. DC motor works on direct current.

C. Rotary Quadrature Encoder

Encoders are used in robotic application for precise and smooth movement of robot. Encoders are specified by output pulses per revolution (PPR). There are mainly two types of encoder incremental and absolute. For the robotic system, Quadrature incremental encoders are used which have certain advantages over other type of encoders. Quadrature encoder has two separate channels that are channel A and channel B and also have four possible states (10, 01, 11, 00).

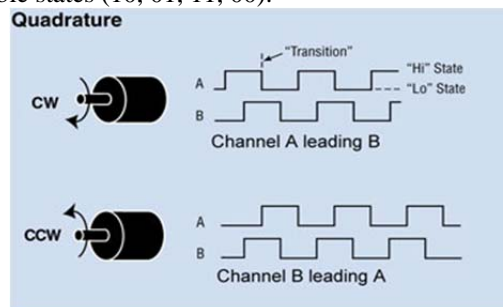

D. Motor Driver (L298)

Motor driver is used to amplify signal coming from microcontroller and give output to motor. Normally it works as a power bridge between microcontroller and dc motor. L298 is dual H Bridge motor driver. There are two enable pins which are connected to microcontroller PWM pin for power control. This gives up to 4A output current and operates up to 46v.

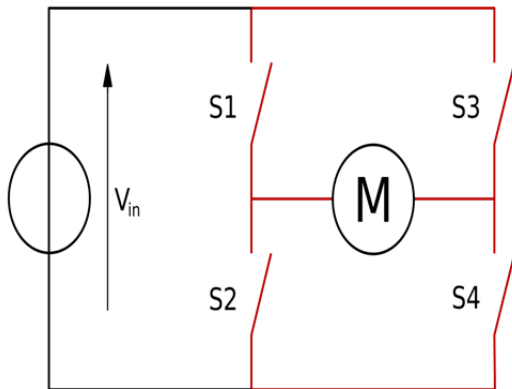

S1	S2	S3	S4	Motor direction
1	0	1	0	Clockwise
0	1	0	1	Anticlockwise
1	1	1	1	No effect
0	0	0	0	No effect

E. HC05 Bluetooth module

Out of various wireless technologies, Bluetooth technology is used in our paper due to its reliability and compatibility with smartphone. HC-05 has versatile application as it can be used in two different modes: 1.Slave 2.Master

In this paper, HC05 is going to be used in slave mode. UART technology is used for communication between microcontroller and hc05 module.

SIGNIFICANCE OF PID

PID controllers are commercially very successful and widely used in industries all over the world. PID controller consists of proportional controller, integral controller and derivative controller. Depending upon requirement one or more combinations of controllers can be used in the system. In robotic system, robot takes feedback from the sensors to know how faraway the system is from target and then adjust the output of the system to achieve the target.

Equation for PID controller is-

$$K_p e(t) + \frac{K_p}{T_i} \int_{-\infty}^t e(t) + K_p T_d \frac{de(t)}{dt}$$

Proportional term of the equation is directly proportional to the error in the system. Initially system is at rest hence to achieve the set-point quickly, system will get overshoot and induce the small negative error. That small

negative error will make the system oscillate and system will settle down at some point below the set-point inducing Steady State Error (SSE).

To remove Steady State Error (SSE), we need to add integral term. Integral term causes the high overshoot to the system output initially because it accumulates the errors from the past. Initially when system is at rest, error is very large so it makes the integral term to shoot the system far above set-point. Due to this characteristic of the integral term, system oscillates around the set-point before settling it down. There is no Steady State Error in the system because integral term accumulates the past negative errors and cancels out the positive errors.

In context of PID, derivative is the rate at which error is changing. If error is decreasing at faster rate then system gets closer to the set-point faster. So to slow down the system as it reaches near the set-point, we use derivative term of PID. It makes the system settle down at the set-point with very few or no oscillations around the set-point. Hence, the settling time of the system gets reduced significantly. In this way, PID controller helps the system to achieve the set-point in more controlled way.

V. CONCLUSION

Hence, we conclude this paper by providing the design architecture for creating a robotic system which can be controlled very easily and can be implemented in various parts of daily life. Main objective of this paper is providing robotic architecture which can be controlled by smart phone with Bluetooth technology. The robotic system architecture proposed in this paper is very scalable .Further development of this system can be done by enhancing the hardware performance and by adding more features. The potential of system can be increased by adding more features like Wi-Fi connectivity, robotic arms, camera and different types of sensors. Main advantage of this system is use of smart phone as a remote control which is easily available and can be replaced at low cost. Connectivity between robot and smart phone can also be established using Wi-Fi or Internet to improve the communication and data exchange. If connectivity is established using Internet then in context of IOT this system architecture has great scope of implementation in various aspects of human life.

ACKNOWLEDGEMENT

We are having great pleasure presenting our paper ‘Robotic Control Using an Android Application’. We have tried our best to cover all the required details related to the topic. Wholehearted co-operation and dedicated efforts of all team members have resulted into the successful completion of this paper.

We would like to express our sincere gratitude to Prof. Anita Shinde who guided us throughout the preparation of this paper. Her inputs and suggestions helped us to improve this paper. We thank her for providing us valuable suggestions and track of the topic.

We would also like to thank our friends for reviewing the paper, highlighting the mistakes and giving valuable inputs.

REFERENCES

- [1] Design of a Bluetooth Enabled Android Application for a Microcontroller Driven Robot By Vito M. Guardi,(May 2014).
- [2] Android Controlled Mobile Robot By Jorge Kazacos Winter,(July 2013).
- [3] Android Based Robot Implementation For Pick and Retain of Objects By Ranjith Kumar Goud, B. Santhosh Kumar, (Oct 2014).
- [4] Smart phone based robotic control for surveillance applications By M.Selvam,(IJRET 2014)
- [5] Controlling a Robot using Android Interface and Voice By Kishan Raj KC,(2012).
- [6] Motion Control of Wheeled Mobile Robot By Gyula Mester,(SISY 2006)
- [7] Design of PI and PID Controllers with Transient Performance Specification By J. C. Basilio and S. R. Matos,(IEEE 2002).